

Flansch-Kugelhähne aus Stahlguß

Flange-ball valves in carbon steel

Baureihe
71MS

mit vollem Durchgang
full port design

DN15-DN100 PN16+PN40
DN125-DN200 PN16



Konstruktions-Merkmale

Bauart:

- zweiteiliges Gehäuse
- voller Durchgang
- TA-Luft
- Fire-Safe Zulassung (optional)
- VD-TÜV (optional)
- DVGW (optional)
- Antistatikausführung
- ausblässichere Schaltwelle
- silikonfrei

Aufbauten:

- Montageflansch nach DIN ISO 5211
- lieferbar mit pneumatischem oder elektrischem Drehantrieb
- Direktaufbau möglich
- Spindelverlängerung aus Stahl (Edelstahl auf Anfrage)

Kugeldichtung:

- 3-seitige Kammerung
- verschiedene Dichtungssysteme lieferbar

Abmessungen:

Flansch-Kugelhähne nach DIN 3357
Baulängen nach EN 558-1
Dichtflächen nach EN 1092-1 B1
(andere Ausführungen auf Anfrage)
Flanschanschlussmaße nach EN 1092-1

Temperaturbereich:

Gas - 20°C bis + 60°C
allgemein - 20°C bis + 180°C
(abhängig vom Betriebsdruck und Dichtsystem)
andere Temperaturbereiche auf Anfrage

Verwendung:

Wasser, Öle, Kraftstoffe,
Gas, Druckluft

Design features

design:

- two-piece ball valve
- full port design
- TA-Luft
- fire-safe tested (optional)
- VD-TÜV (optional)
- DVGW (optional)
- antistatic - device
- blow out proof stem design
- free of silicone

mounting:

- mounting flange acc. to DIN ISO 5211
- available with electrical or pneumatic actuators

- direct mounting possible

- stem extension steel
(stainless steel connections on request)

stem seal:

- 3-side covered
- different seal systems available

dimensions:

flange ball valves, acc. to DIN 3357
length of complete valve acc. to EN 558-1
faces acc. to EN 1092-1 B1
(other types on request)
flange dimensions acc. to EN 1092-1

working temperature:

Gas - 20°C to + 60°C
in general -20°C to + 180°C
(depending on working pressure and seal system)
different temperature ranges on request

suitable for:

water, oils, fuels
gas, compressed air

Auslegungsbeispiele für die Dichtungssysteme

Design for sealseystem

		Dichtungssystem		Bemerkung remark
		PN16	PN40	
Wasser	<i>water</i>	E	E	
Dampf	<i>steam</i>	G	G	≤ DN50 max. 215°C, 21bar ≤ DN100 max. 212°C, 20bar
Gas Druckluft Koksofengas Flugasche	<i>gas compressed air coke ovengas fly ash</i>	A E a.A a.A	B E -- --	
Kraftstoffe (Diesel etc.) Öle Lösemittel	<i>fuels oils solvents</i>	E	E	optional Druck- entlastungs- bohrung <i>optional vent hole</i>

Tabelle / table 1

		Dichtungssystem		Bemerkung remark
		PN16	PN40	
Sauerstoff Stickstoff	<i>oxygen nitrogen</i>	A A	B B	
Isocyanat Polyol	<i>Isocyanat Polyol</i>	E E	E E	trocken dry
Hochtemp. od. Wärmeträgeröl		D	D	max. 400°C
Fire-Safe-Ausf.		S	S	
Hochtemp.		H	H	max. 250°C

Dichtungssysteme für unterschiedliche Anwendungen





seal systems for different applications

Tabelle / table 2

Dichtungssystem seal system	Kugeldichtung ball seal	Spindeldichtung stem seal	Gehäusedichtung body seal	Zulassungen certifications	Bestellcode für Zulassungen ordering code for seal system
A	PTFE	PTFE + FKM	PTFE+FKM	TA-LUFT / Vd-TÜV PED / Gas PN16	0/1/5
B	PTFE/TFM	PTFE + FKM	PTFE+FKM	TA-LUFT / Vd-TÜV PED / Gas PN40	0/3/5
D	Antimony Carbon	Graphite	Graphite	-----	0
E	PTFE + GF	PTFE + FKM	PTFE+FKM	TA-LUFT / Vd-TÜV PED	0/5/7
G	PTFE /TFM	PTFE + EPDM	PTFE+FKM	TA-LUFT / Vd-TÜV / PED	0/5
H	Peek	Graphite	Graphite	PED	-----
S	PTFE + GF	Fire Safe (FKM+ PTFE + Graphite)	Graphite+FKM	TA-LUFT / Fire Safe acc. and ISO 10497	6
T	PTFE Cavity filler	PTFE + FKM	PTFE + FKM	TA-LUFT / PED	0

Bestellcode für Zulassungen ordering code for certification

Tabelle / table 3

	TA LUFT ISO 15848-1/VDI 2440 (Standard, ohne Kennzeichnung und Mehrpreis) (Standard version without additional costs)	0
	DVGW DG-4313BU0129 DIN EN 13774 PN 16 für Gase nach G260/1	1
	DVGW DG-4314BU0131 DIN EN 14141 PN 40 für Gase nach G260/1	3
	Vd TÜV Armatur 100 AD 2000 TÜV. A 353-09 Vd TÜV (Mehrpreise - siehe Bildpreisliste) (additional costs acc. to price list)	5
	Fire Safe ISO 10497 TÜV IS-DDB-MAN/001/08	6
	GGVSEB/ADR/RID TÜ.AGG.429.09 DIN EN 14432	7

Bestellangaben (Beispiel)

Ordering data (example) Tabelle / table 4

71MS	- 50	- 16	- F	- E	- R27	- 0
Baureihe / series	Nennweite / diameter	Druckstufe / pressure rating	Kugel / ball	Dichtungssystem / A / B / D / E / G / H / S / T seal system	Baulänge / EN 558 Reihe 27 / Reihe 1 length EN 558 line 27 / line 1	Benötigte Zulassungen required registrations

Der Kugelhahn ist mit den aufgeführten Zulassungen lieferbar
(siehe auch Bestellangaben):
This valve is available with the shown certifications
(acc. to ordering dates)

Falls bei der Bestellung nicht näher spezifiziert
liefern wir den Standard: 71MS-DN-16-F-E-R27-0
In case of no order specification we
supply our standard: 71MS-DN-16-F-E-R27-0

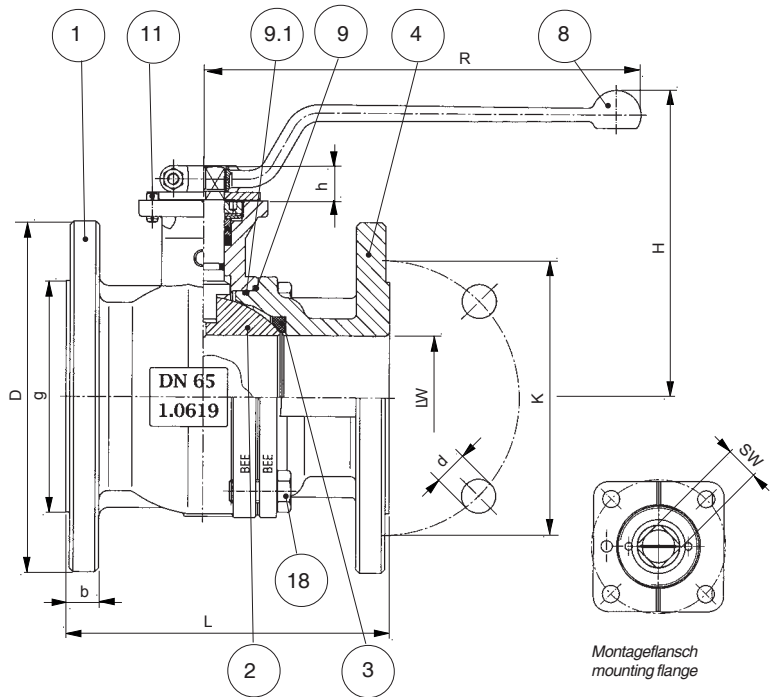

Standard

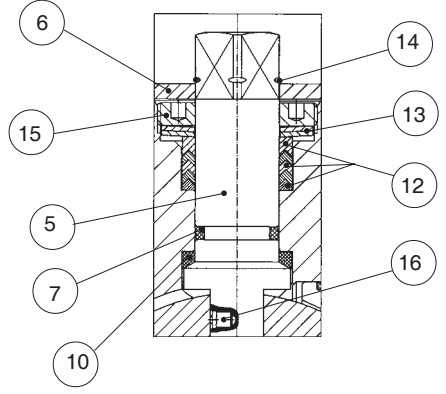

Montageflansch
mounting flange

Fire-Safe

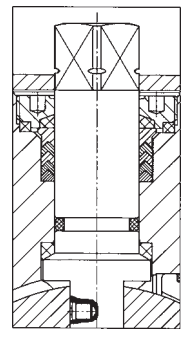

Nr./no	Bezeichnung	description	Werkstoff	material	Material-Bezeichnung
1	Gehäuse	body	Stahlguß	carbon steel	1.0619
2	Kugel	ball	Edelstahl	stainless steel	1.4408
*3	Kugeldichtung	ballseal	-	-	-
4	Flansch	flange	Stahlguß	carbon steel	1.0619
5	Schaltwelle	stem	Edelstahl	stainless steel	1.4404
6	Anschlagscheibe	stop plate	Stahl verz.	steel zinc plated	-
*7	O-Ring	O-ring seal	-	-	-
8	Griff	handle	Stahl verz.	steel zinc plated	1.0619
*9	Gehäusedichtring	gasket	-	-	-
9.1	O-Ring	O-ring	FKM Viton	FKM viton	-
10	Anlauftring	thrust washer	PTFE + GF	PTFE + GF	-
11	Anschlagstift	stop pin	Stahl verz.	steel zinc plated	-
*12	Packung	packing	-	-	-
13	Tellerfeder	spring plate	Edelstahl	stainless steel	1.4310
14	Federring	clip ring	A2	A2	-
15	Überwurfmutter	nut	Edelstahl	stainless steel	1.4404
16	fed. Druckstück	spring pressure piece	A2	A2	-
18	Skt.-Schraube	screw	Stahl verz.	steel zinc plated	8.8

* siehe Tabelle Dichtungssysteme
* see table seal systems

Stückliste Standard
Partlist standard

DN LW	Reihe/Line		H	R	SW	h	Montageflansch Mounting flange DIN ISO 5211	PN 16						PN 40						Gewicht weight ~kg	
	R 27	R 1						D	g	K	b	z	d	D	g	K	b	z	d	R 27	R 1
15	115	130	99,0	138	9	9	F 03	95	45	65	15	4	14	95	45	65	15	4	14	2,35	2,55
20	120	150	104,5	138	9	9,5	F 03	105	58	75	17,5	4	14	105	58	75	17,5	4	14	2,95	3,35
25	125	160	109,0	165	11	12,5	F 05	115	68	85	17	4	14	115	68	85	17	4	14	4,10	4,50
32	130	180	120,5	165	11	12,5	F 05	140	78	100	17,5	4	18	140	78	100	17,5	4	18	5,60	6,20
40	140	200	132,5	200	14	14	F 05	150	88	110	17	4	18	150	88	110	17	4	18	6,65	7,35
50	150	230	140,5	200	14	14	F 05	165	102	125	19	4	18	165	102	125	19	4	18	9,10	9,80
65 PN 16	170	290	163,0	230	17	18	F 07	185	122	145	17,5	4	18							13,30	15,85
65 PN 40	170	290	163,0	230	17	18	F 07							185	122	145	21	8	18	14,30	17,30
80	180	310	196,0	365	22	22,2	F 10	200	138	160	23	8	18	200	138	160	23	8	18	19,20	22,00
100 PN 16	190	350	212,5	365	22	22,3	F 10	220	158	180	19	8	18							25,50	29,90
100 PN 40	190	350	212,5	365	22	22,3	F 10							235	162	190	23	8	22	29,60	34,40
125	325		238,5	565	27	27	F10 / F12	250	188	210	21	8	18							46,20	
150	350		260,5	565	27	27	F10 / F12	285	212	240	21	8	22,5							71,00	
200	400		303	745	27	28	F12 / F14	340	268	295	23	12	22,5							125,00	

Druck-Temperaturdiagramme
pressure temperature diagram

Dichtsystem B + G
seal system B + G

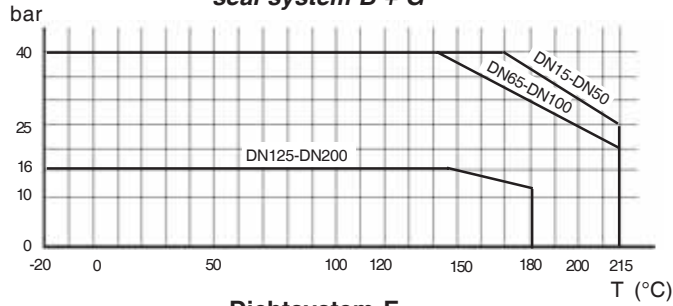

Dichtsystem E
seal system E

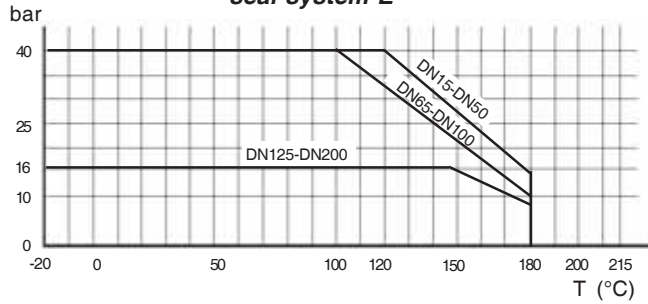

Dichtsystem A + T
seal system A + T

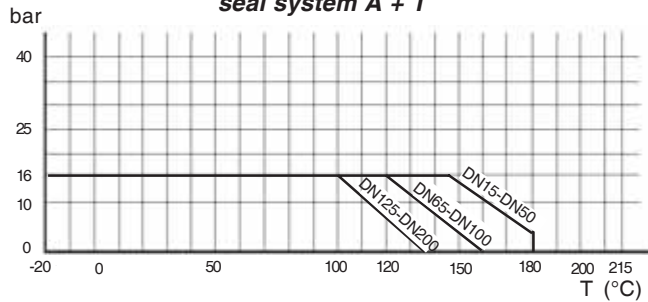

Dichtsystem H
seal system H



Folgende Schaltmomente wurden an neuen Kugelhähnen ermittelt. Entsprechend der Anwendung müssen geeignete Sicherheitswerte bei der Antriebsauslegung berücksichtigt werden.
Following operating torques were determined from stock valves. According to there application a appropriate safety factor must be taken under consideration.

Schaltmomente in Nm der Dichtsysteme / operating torque Nm acc. to the seal system													
Druck in bar	0			7			16			25		40	
DN	A+T	B+G	E	A+T	B+G	E	A+T	B+G	E	B+G	E	B+G	E
15		3	1		2	1,2		3	1,5	3	1,7	4	15
20		3	4		4	4,2		4	4,6	5	4,6	6	20
25		6	4		5	4,2		5	4,5	6	4,5	8	25
32		10	7		11	7,2		10	7,5	10	8,0	13	32
40		12	8		9	8,2		12	8,5	14	9,0	17	40
50		12	9		12	15		13	22	16	27,0	24	50
65		19	10		24	17		35	22	36	25,0	50	65
80		22	15		25	20		34	30	38	28,0	50	80
100		55	15		66	35		82	55	89	67,0	105	100
125	40	60	20	80	100	70	100	180	140	--	---	---	---
150	60-80	60	25-40	100	140	125	160	290	190	--	---	---	---
200	100	80	40-60	110	350	210	350	380	480	--	---	---	---